



Polymer Engineering Department

Production technology – thermoplastic processing

Production technology – thermoplastic processing

Process development for the large-scale processing of thermoplastic polymers is a key task of the research groups for injection and compression molding and structural composites in the Polymer Engineering Department of the Fraunhofer Institute for Chemical Technology ICT. Beside standard injection molding and compression molding, emphasis is placed on one-step resource- and energy-efficient direct processes, for example for long-fiber-reinforced thermoplastics (LFTs) with local continuous-fiber reinforcement.



Fiberforge - technology for the fully automated processing of unidirectional fiber-reinforced thermoplastic tapes (UD stacking); side view of the motion table



ARBURG Allrounder 320 C 600-250



ENGEL ES 200/60 LH ST

Injection molding machines

ARBURG Allrounder 320 C 600-250

Injection unit

Screw diameter	mm	30
Max. feeding stroke	mm	150
Shot volume	cm ³	106
Injection pressure	bar	2470
Max. cylinder temperature	°C	450

Thermoset injection unit

Screw diameter	mm	30
Max. feeding stroke	mm	150
Shot volume	cm ³	106
Injection pressure	bar	2470
Max. cylinder temperature	°C	120

Clamping unit

Clamping force	kN	600
Tie-bar spacing	mm	320
Min. mold height	mm	200
Max. mold opening stroke	mm	350

Additional equipment

- Clamping unit with hydraulic pivot
- Injection compression molding (precision opening)
- Servo-controlled injection unit
- 4 operating positions (including injection into the parting line when parting line is positioned vertically or horizontally)

ENGEL ES 200/60 LH ST

Injection unit

Screw diameter	mm	30
Max. feeding stroke	mm	140
Shot volume	cm ³	99
Injection pressure	bar	2150
Max. cylinder temperature	°C	500

Clamping unit

Clamping force	kN	600
Tie-bar spacing	mm	–
Min. mold height	mm	200
Max. mold opening stroke	mm	450

Additional equipment

- Tie-barless clamping unit
- Injection compression molding
- Handling device for removing molded part



ENGEL victory 330/120 tech

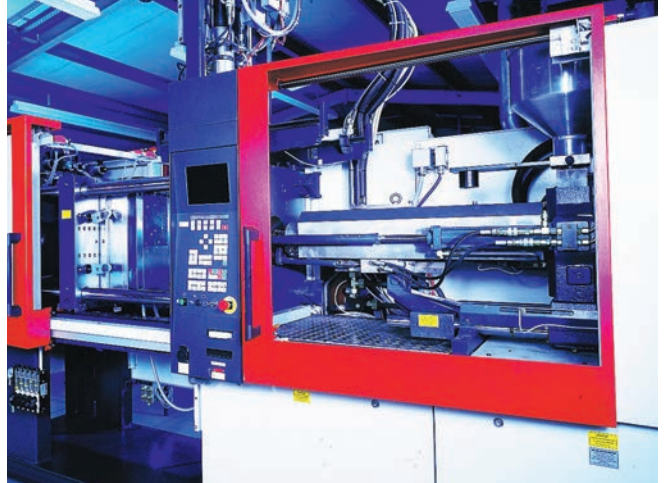

Ferromatik Milacron K110

Injection molding machines

ENGEL victory 330/120 tech

Injection unit 1

Screw diameter	mm	30
Max. feeding stroke	cm ³	113
Max. injection pressure	bar	2180
Max. injection rate	cm ³ /s	111
Max. cylinder temperature	°C	450
L/D		23.6

Injection unit 2

Screw diameter	mm	40
Max. feeding stroke	cm ³	201
Max. injection pressure	bar	1225
Max. injection rate	cm ³ /s	198
Max. cylinder temperature	°C	450
L/D		17.5

Clamping unit		
Clamping force	kN	1200
Clamping plate h x v	mm	740 x 680
Min. mold height	mm	300
Max. mold opening stroke	mm	500

Specialized processes

- Injection compression molding

Additional equipment

- Handling system e-pic
- Tie-barless clamping unit
- Single mold nozzle control (hydraulic)
- Rotating bolt shut-off nozzle
- Duplex core pullers

Ferromatik Milacron K110

Horizontal injection unit

Screw diameter	mm	45
Max. feeding stroke	mm	160
Shot volume	cm	254
Injection pressure	bar	1936
Max. cylinder temperature	°C	350

Vertical injection unit

Screw diameter	mm	35
Max. feeding stroke	mm	140
Shot volume	cm ³	135
Injection pressure	bar	1964
Max. cylinder temperature	°C	350

Clamping unit

Clamping force	kN	1100
Tie-bar spacing	mm	470
Min. mold height	mm	250
Max. mold opening stroke	mm	550

Additional equipment

- 2-component injection molding
- GIT mold nozzle or machine nozzle
- Push-pull injection molding
- Mono sandwich injection molding
- 2 core pullers (hydraulic)

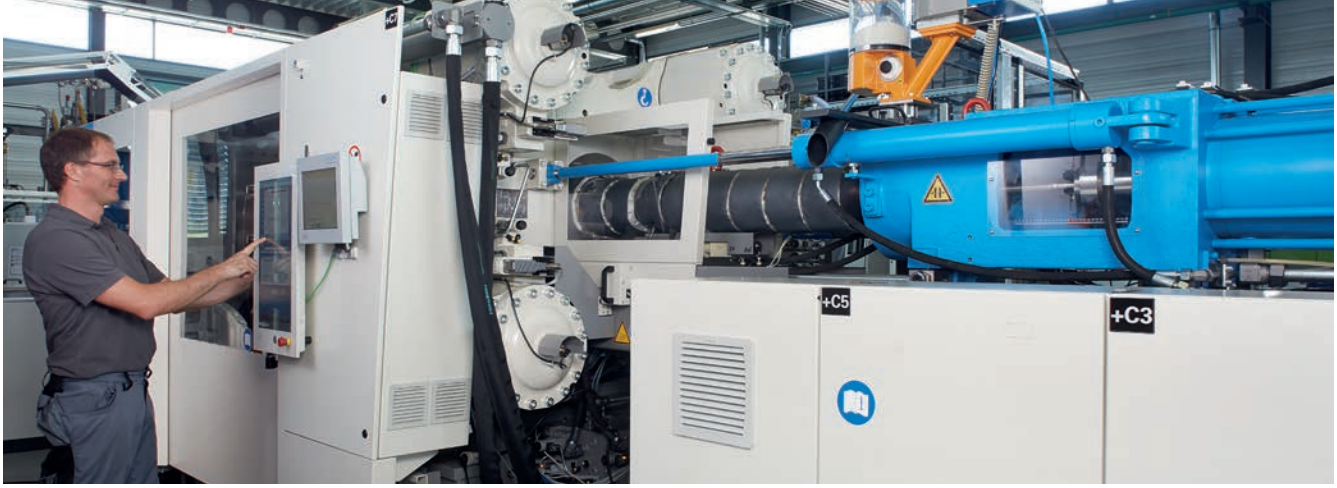

KraussMaffei KM 550-2000 GX

KraussMaffei KM 550-2000 GX

Thermoplastic injection unit

Screw diameter	mm	60
Max. feeding stroke	cm ³	792
Max. injection pressure	bar	2057
Max. injection speed	cm ³ /s	848
Max. cylinder temperature	°C	450
L/D 23		

MuCell® injection unit

Screw diameter	mm	60
Max. feeding stroke	cm ³	792
Max. injection pressure	bar	2057
Max. injection speed	cm ³ /s	848
Max. cylinder temperature	°C	450
L/D 23, standard screw		

Thermoset injection unit

Screw diameter	mm	60
Max. feeding stroke	cm ³	792
Max. injection pressure	bar	2420
Max. injection speed	cm ³ /s	848
Max. cylinder temperature	°C	450
Standard screw		

Clamping unit

Clamping force	kN	5500
Tie-bar spacing h x v	mm	1400 x 910
Min. mold height	mm	400
Max. mold opening stroke	mm	950
Max. clamping unit stroke	mm	1350

Specialized processes

- MuCell® process
- DuroSet process
- Injection compression molding/precision opening (parallel control)

Additional equipment

- Handling robot KUKA KR 90 R2700 pro
- APC Plus (adaptive process control)
- Needle valve nozzle
- Rotating bolt shut-off nozzle
- Controlling device for 6 cascades (pneumatic)
- Controlling device for 6 cascades (hydraulic)
- 6 core pullers
- Pressure accumulator
- Mold hot runner control system (32 zones)



Engel Duo 700 Pico Combi M Compounder

Injection molding machines

ENGEL Duo 700 PICO Combi M Compounder

Injection unit

Screw diameter	mm	105
Max. feeding stroke	cm ³	4160
Max. injection pressure	bar	2090
Max. cylinder temperature	°C	450
L/D 25 3D mixing and shearing part		

MuCell® injection unit

Screw diameter	mm	80
Max. shot volume	cm ³	1558
Injection pressure	bar	1640
Max. injection speed	cm ³ /s	443
Max. cylinder temperature	°C	350
L/D 22, LFT screw (X8000)		

Clamping unit

Clamping force	kN	7000
Tie-bar distance h x v	mm	1100/960
Min. mold height	mm	450
Max. mold opening stroke	mm	1400
Max. clamping unit stroke	mm	1845

Center plate

Min. mold height	mm	225
Max. mold opening stroke	mm	700

Extruder (Leistritz ZSE 40 Maxx 48D)

Processing section length	L/D	48
Screw diameter	mm	40
Max. rotation speed	1/min	600
Max. cylinder temperature	°C	350
Side feeder	Ø	36

Specialized processes

- Direct injection molding process (in-line compounding)
- MuCell® process
- LFT-D foam / direct foam process
- 2-component injection molding
- Rotary table with mountable center plate
- Injection compression molding (precision opening/parallel control)

Other aspects

- Handling robot VIPER40
- Cascading control (pneumatic)
- Shut-off nozzle
- 8 core pullers



ARBURG SPE 460

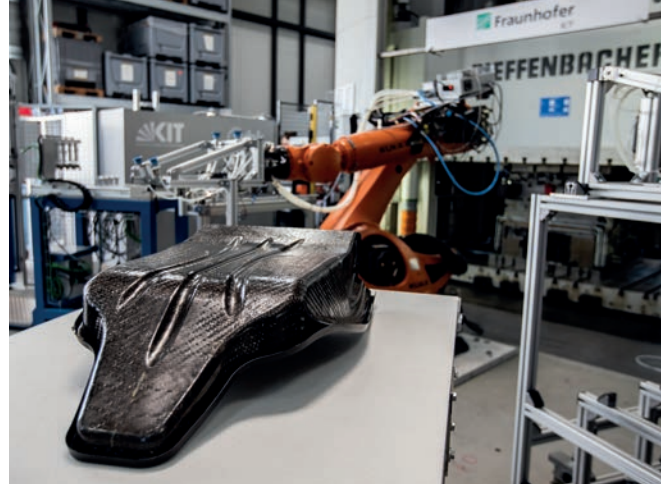

KUKA Robot KR 210 R2700 prime

ARBURG SPE 460/Dieffenbacher Compress Plus DCP-G 3600/3200 AS

Injection unit

Screw diameter	mm	90
Shot volume	cm ³	2290
Injection pressure	bar	2000
Max. cylinder temperature	°C	450
L/D		22.5

FDC Injection unit

Screw diameter	mm	80
Shot volume	cm ³	1810
Injection pressure	bar	2500
Max. cylinder temperature	°C	350
L/D		31.3
Max. injection rate	cm ³ /s	240

Hot-runner adapter plate for use with standard injection molds

90°- Hot-runner redirection up to 450 °C		
Needle valve nozzle		
Max. mold depth	mm	1300
Max. mold length	mm	1900
Max. mold height	mm	980

Horizontal clamping unit Dieffenbacher-Press

Max. load centered/clamping force	kN	36000
Max. load centered with		
Max. force with parallel control	kN	32000
Min. mold height	mm	750
Max. mold height	mm	1.500
Height range of sprue bushing	mm	600-1100
Max. stroke with parallel control	mm	100
Max. opening stroke	mm	2150
Max. mold depth	mm	2900
Max. mold length	mm	2.100

Special procedure

Fiber direct compounding (FDC)		
– max. number of Rovings		6
– cutting lengths	mm	5.6/11.2/ 16.8/33.6

Injection compression molding (precision opening/parallel control)

Other

- Handling robot KUKA Robot KR 210 R2700 prime
- Controlling device for 8 cascades (pneumatic)
- 64 zones - mold hot runner control system



Dieffenbacher
Hydraulic Press DYL630/500

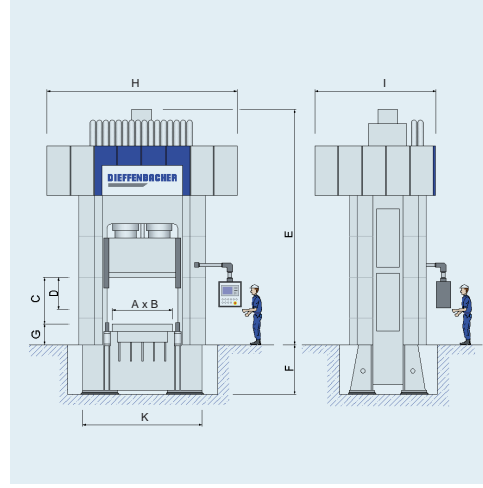

Source: Dieffenbacher



Dieffenbacher
Hydraulic Press DCP-G 3600/3200 AS

Presses

Dieffenbacher Hydraulic Press DYL630/500 with parallel motion control

Data

Max. load centered	kN	6300
Max. load centered with parallel control	kN	5000
Max. opening force	kN	1300
Max. parallel control	kN	1300

Table size

Length A	mm	1600
Depth B	mm	1300

Mold size

Length max.	mm	1500
Depth max.	mm	1200
Height min.	mm	300
Height max.	mm	1000

Mold position

D max.	mm	1600
C min.	mm	2150
Stroke max.	mm	1300

Dieffenbacher Hydraulic Press Compress plus DCP-G 3600/3200 AS

Data

Max. load centered	kN	36,000
Max. load centered with parallel control	kN	32,000
Max. opening force	kN	2000
Max. parallel control	kN	4000

Table size

Length A	mm	3000
Depth B	mm	2000

Mold size

Length max.	mm	2900
Depth max.	mm	1900
Height min.	mm	750
Height max.	mm	1500

Mold position

D max.	mm	2900
C min	mm	2150
Stroke max.	mm	2150

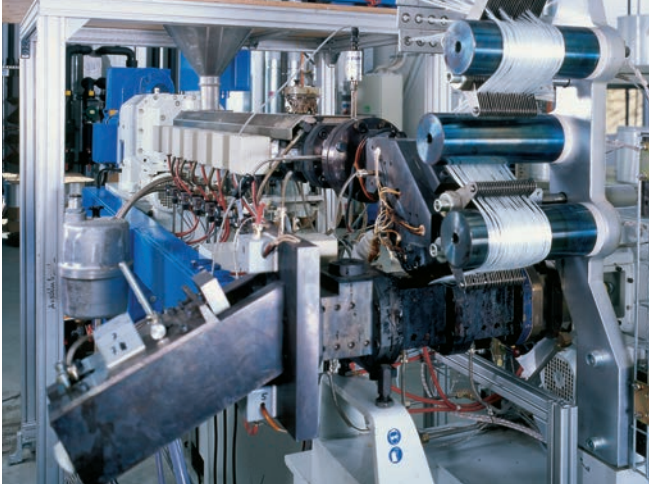

LFT-D line



Dieffenbacher Fiberforge 4.0

LFT-D and tape laying technology

LFT-D line with in-line compounding for material development

In-line compounder

- Leistritz ZSE-40 HP
- Processing section length: 32D
- Two point vacuum degassing system
- Side feeder

Mixing extruder

- Leistritz ZSG-40 GL
- Processing section length: 14D or 20D

Glass fiber dosage

- Direct rovings
- In-line short fibers
- Mechanical nozzle 75 mm or 175 mm

Dosing unit

- 3 Brabender dosing units for granulates
- 1 Brabender dosing unit for powder

Maximum throughput

- 4 kg/min (with PP/GF20)

Combinable with Dieffenbacher DYL 630/500 press

Dieffenbacher Fiberforge 4.0

Technical data

Diameter display table	mm	2000
Number of laying beams		2
Number of tape spools		4
Number of cutting heads		2
Cycle times (without welding)	sec/tape	1.35
Material throughput	kg/h	490
Min. tape length per course	mm	50
Max. tape length per course	mm	2000
Max. square lay-up dimension	mm	1400 × 1400
Angular cut	°	+45 bis -45
Controllable gap/ overlap	mm	-2 to +5
Processable tape widths	mm	50 to 165
Processable tape thicknesses	mm	0.1 to 0.4



Dieffenbacher Fibercon

Tape material consolidation

Radiation-induced vacuum consolidation

Technical data

Min. lay-up dimension	mm	350 × 350
Max. lay-up dimension	mm	400 × 400
Max. temperature	°C	450
– patented prototype unit		
– inert vacuum atmosphere		
– PID-controlled heating cycles		
– uniform and non-uniform wall-thickness profile can be produced		
– release agent-free processing for many types of materials		

Hydraulic press for consolidation

Technical data

Max. load centered	kN	2000
Max. lay-up dimension	mm	1000 × 1000
Max. temperature	°C	425

Table size

Length	mm	1400
Depth	mm	1100

Dieffenbacher Fibercon

Technical data

Max. lay-up dimension	mm	1740 × 940
Max. temperature	°C	450
– based on radiation-induced vacuum consolidation		
– inert vacuum atmosphere		
– PID-controlled heating cycles		
– possibility to produce profiles with uniform and non-uniform wall thickness		
– processing without release agents for multiple material types		

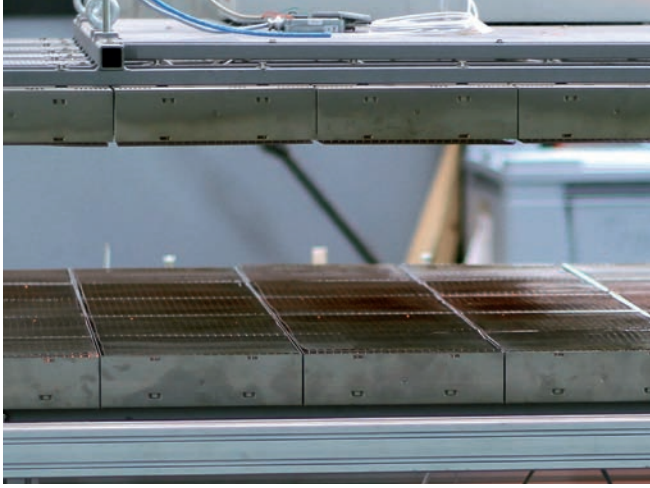

Infrared heating system

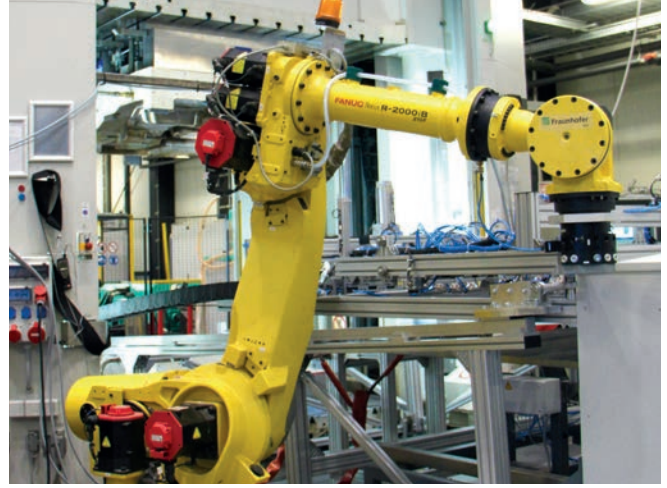

Robot Fanuc R-2000IB/210F

Heating technology and automation

Contact heating systems

Data			
Size	mm	1100 × 1100	
Heating power	kW	2 × 50	
Max. temperature	°C	425	

Infrared heating systems

Data		Mobile system small	Mobile system large	Integrated system
Size	mm	750 × 750	1450 × 1720	1250 × 1500
Heating power	kW	2 × 22.5	168	2 × 75
Max. temperature	°C	500	500	500

Convection oven

Data		Batch-type oven
Size	mm	450 × 600 × 500
Heating power	kW	5.8
Max. temperature	°C	450

Convection oven »HK Passat L«

Data		Batch-type oven
Size of gratings	mm	2550 × 1800
Heating power	kW	97.2
Max. part height	mm	50
Max. part weight	kg	20
Number of gratings		8
Max. temperature	°C	300

Robot Fanuc R-2000IB/210F

Technical data

Controlled axes	no.	6
Max. load capacity	kg	210
Reach	mm	2655

- More flexible design of manufacturing cells
- Reduction of cycle times
- High speed of controlled axes
- Fast rotation of parts possible

Contact

Injection and Compression Molding:

Dipl.-Ing. Andreas Menrath

Phone +49 721 4640-421

Mobile +49 172 2128 444

andreas.menrath@ict.fraunhofer.de

Structural Composites:

Dr.-Ing. Michael Wilhelm

Phone +49 721 4640-746

Mobile +49 173 4226 230

michael.wilhelm@ict.fraunhofer.de

Director:

Prof. Dr.-Ing. Frank Henning

Phone +49 721 4640-420

Fraunhofer Institute for
Chemical Technology ICT
Joseph-von-Fraunhofer-Straße 7
76327 Pfinztal (Germany)

www.ict.fraunhofer.de